

HELIOS i2/i3

Helios i2/i3 sind hochauflösende LED Displays und perfekt für ein breites Spektrum von Indoor-Anwendungen geeignet. Mit dem Pixelabstand von 2,6 mm bzw. 3,9 mm sind diese Produkte ideal für Einsätze, bei denen hohe Auflösungen gefordert sind.

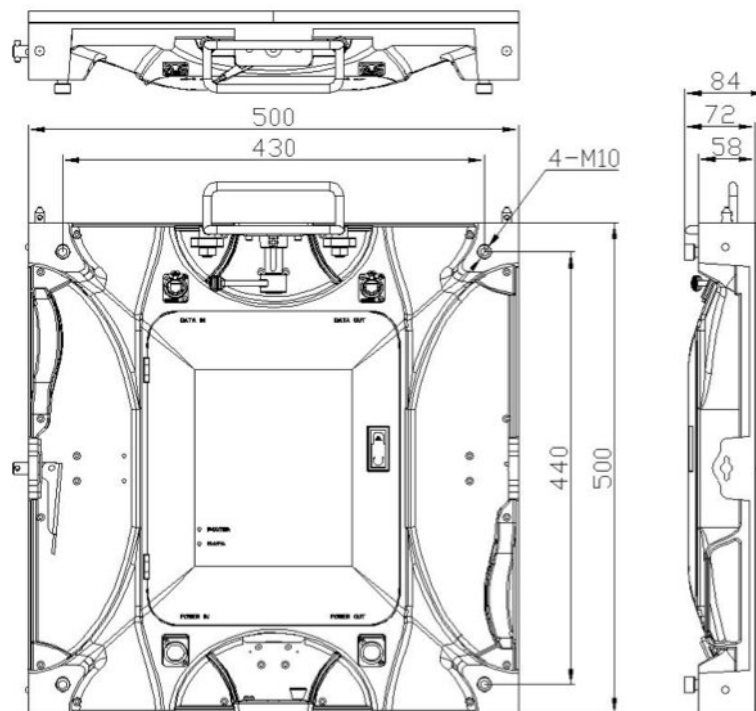

HELIOS 12/13

Technische Daten

Pixel Pitch	2,6 mm / 3,9 mm
LED Type	3 in 1 SMD 2121 HQI black-face
Pixel per Panel	192x192 / 128x128 Dots
Processing Depth	16 Bit
Rate Refresh	≥ 3.200 Hz
Brightness	1.200 cd/m ²
Viewing Angle	H: 120° / V: 100°
Cabinet Size	500 x 500 x 85 mm
Cabinet Weight	9,2 kg / 8,5 kg
Ingress Protection	Front: IP30
Curve (optional)	-/-
Service Method (only fixed installation)	front/rear
Input Voltage	110 / 220 VAC ±10%
Input Power Frequency	47 bis 63 Hz
Input Power (max.)	135 W/Panel
Input Power (typical)	45 W/Panel
Life Time (only fixed installation)	≥ 100.000 Hours

Corner Cabinet

