

JVC[®]

The Perfect Experience / —
/

HD/SD Memory Card Camcorder

GY-HM750U

ProHD



Supremely Flexible

The above picture shows the GY-HM750U with the optional battery.

Fully Compatible with Current and Future Production Workflows

Dual recording and native support for Final Cut Pro™ in HD or SD

Introducing the GY-HM750U, a highly mobile, professional dual memory card camcorder with the flexibility to fit seamlessly into almost any production environment. For both HD and SD assignments, the camcorder natively records Apple's QuickTime™ (MOV) file format for Final Cut Pro™ for a smooth, hassle-free workflow. For compatibility with other NLE systems, the GY-HM750U also supports HD MP4 and SD AVI file recording

Dual memory card slots offer the flexibility of seamless relay recording or simultaneous recording for instant backups and duplicates.



Simultaneous Recording to Dual SDHC Memory Cards

Dual SDHC memory card slots allow for either relay recording for almost unlimited shooting times, or simultaneous recording for backups or duplicates without the need for any additional equipment.



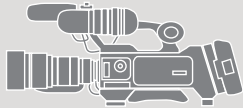

MOV QuickTime™ MP4 AVI DV

SDHC SxS (SxS for MP4 only)

HD Rec

SD Rec

HD SD



HD/SD Shooting



In the transition period from SD to HD production, camcorders must be able to meet the requirements of both without compromising image quality or features. The GY-HM750U meets this challenge by providing a true SD shooting mode in standard DV 25 Mbps format, recording to either MOV or AVI file format for direct editing within NLE systems.

Native File Recording



Record footage directly in ready-to-edit QuickTime™ MOV files, the native file format of Apple's Final Cut Pro™, or in MP4 format (XDCAM EX™ workflow-compatible) for direct editing in other major NLE systems, including Avid Media Composer, Adobe Premiere and Canopus Edius Pro. Native file recording means no transcoding or file-wrapping is necessary, resulting in more efficient workflows and no loss of image quality.



The Choice of Broadcasting and Cinematography Professionals

Drawing on its long experience of developing dedicated encoders for the broadcasting industry, JVC has equipped the GY-HM750U with a powerful MPEG2 encoder capable of compressing full 1920 x 1080 HD video at up to 35 Mbps. The result is the pristine picture quality that professional users demand, from a surprisingly compact and lightweight shoulder-mount camcorder.



Workflow

With Native File Recording, JVC has eliminated one of the main obstacles to achieving a smoother, more streamlined production workflow. Until now, getting footage into a file format that computer-based editing systems could work with was a time consuming process. With Native File Recording, your footage is ready to edit the moment it's shot.



35
Mbps

Exceptional Image Quality

Encoding video at higher bit-rates means just one thing: higher image quality. The 35 Mbps data rate used by the GY-HM750U is high enough to support full 1920 x 1080 encoding, and results in stunningly detailed, broadcast-standard HD images.

A custom 1080p Dynamic Digital Signal Processor (DDSP) is the engine that encodes the high bit-rate video signal into an MPEG2 stream and acts as a file compiler for QuickTime™ and MP4 files.



Photo courtesy of KUSI-TV



Photo courtesy of KBMT-TV



Photo courtesy of WKRC-TV



Photo courtesy of American College of Cardiology



Absolute Flexibility in a Compact Shoulder Camcorder GY-HM750U

LCOS Viewfinder

The GY-HM750U features a stunning 16:9 aspect ratio LCOS (Liquid Crystal on Silicon) viewfinder. Thanks to its high resolution, the LCOS viewfinder is crisper and more detailed than conventional LCD viewfinders.



Canon 14x HD Lens

The GY-HM750U is equipped with a high-performance 14x HD lens from Canon, based on the superb optics found in more expensive HD lenses. From wide angle through to telephoto, the lens has pin-sharp focusing accuracy and constant image brightness with no F-drop.

Three 1/3-inch Progressive CCD Design with Triplex Offset

High definition is all about image quality. The 1/3" progressive-scan 3CCD design is enhanced with JVC's original Triplex Offset and Adaptive Pixel Correlation technologies to deliver resolution and color reproduction comparable to cameras with larger image sensors.

1080p Dynamic Digital Signal Processor (DDSP)

JVC's new 1080p Dynamic Digital Signal Processor is the engine that drives the GY-HM750U. This highly efficient MPEG2 encoder processes video signals at up to 35 Mbps for full 1920 x 1080 progressive or interlace video.

Dual SDHC Card Slots with Simultaneous and Relay Recording

The GY-HM750U gives users the flexibility of dual SDHC memory card slots for either simultaneous recording to dual memory cards for an instant backup or duplicate copy, or seamless relay recording between two cards for continuous shooting. For even greater flexibility, the optional SxS media recorder makes possible simultaneous recording to both SxS and SDHC media.

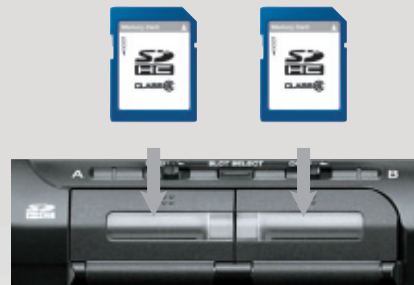

4.3-inch LCD Monitor

The large 16:9 aspect ratio LCD monitor and GUI bring ease of use to a new level for a professional camcorder.

Innovation that Meets the Demands of Professionals — High-Resolution Image Quality



Best-in-Class High Resolution HD Rec

Three 1/3-inch Progressive CCD Design with Triplex Offset

The three progressive CCD design provides rich, accurate colors, while JVC original Triplex Offset technology, in conjunction with pixel correlation, adaptively increases the effective resolution both horizontally and vertically by shifting the red and blue pixels independently relative to the green, for a sharper picture without any corresponding loss in sensitivity. As a result, horizontal, vertical and diagonal resolutions are dramatically increased. Furthermore, using a global shutter, the design minimizes wobbling during quick pans and fixed pattern noise in low light conditions, contributing to a more stable image.

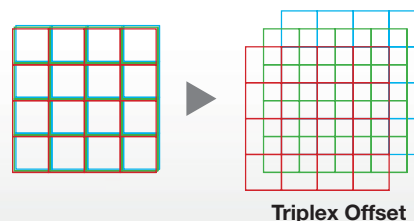
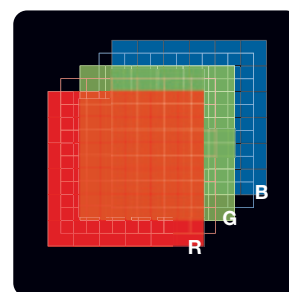
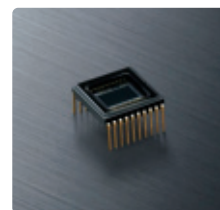
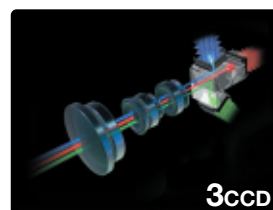

Recording

Canon 14x HD Lens

The JVC GY-HM750U has a standard bayonet lens mount giving users the flexibility of selecting different lenses for different requirements. The standard package includes a high-quality 14x HD lens from Canon, suitable for a wide range of general-purpose applications, with a focal length range of f=4.4–61.6mm (32–448mm at 35mm equivalent).



Advanced MPEG2 High Bit Rate Encoding

1080p Dynamic Digital Signal Processor (DDSP)

At the heart of the GY-HM750U is a custom JVC-developed Dynamic Digital Signal Processor. Processing is performed on the full progressive 1920 x 1080 signal, regardless of the camcorder's settings, ensuring the highest picture quality in any shooting mode. All major HD resolutions are supported, including 1920 x 1080, 1440 x 1080 and 1280 x 720.

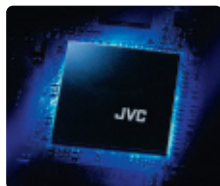

broadcasts, which is still an industry standard in many countries worldwide. This feature offers a fundamental advantage for professionals with time-sensitive SD workflows.

| | HQ mode (35Mbps) | SP mode (25Mbps) | SP mode (19Mbps) | DV mode (25Mbps) |
|-------------|------------------------|------------------|------------------------|------------------|
| 1920 x 1080 | 60i/50i 30p/25p/24p | | | |
| 1440 x 1080 | 60i/50i | 60i/50i | | |
| 1280 x 720 | 60p/50p 30p/25p/24p | | 60p/50p 30p/25p/24p | |
| 720 x 480 | | | | 60i |

* The GY-HM750U supports all major HD signal formats including 1920 x 1080, 1440 x 1080 and 1280 x 720 as well as SD signal in DV codec.

JVC Proprietary 35Mbps MPEG2 Encoder (HD)

Drawing from its experience in developing transmission signal encoders used by major television stations, JVC developed a proprietary codec capable of providing highly efficient compression up to 35 Mbps — high enough to support full 1920 x 1080 encoding — capable of creating high resolution images with minimal artifacts. The XDCAM EX™ MPEG2 long GOP (Group of Pictures) codec is a widely used broadcast-standard compression system and is supported by all popular editing systems and broadcast servers.



The GY-HM750U supports all major HD signal formats including 1920 x 1080, 1440 x 1080 and 1280 x 720.

Uncompressed Audio Recording with Full Manual Control

The GY-HM750U captures audio with the same uncompromising quality as video. Two-channel 16-bit/48 kHz uncompressed linear PCM can be recorded via the detachable shotgun microphone, or via a pair of balanced XLR connectors. Versatile input switching and independent channel assignment allow both mic and line-level sources (such as wireless receivers) to be connected, and phantom power is available on each XLR connector independently. Audio recording levels can be controlled automatically or manually, with an audio level meter in the viewfinder and LCD monitor for easy monitoring.



Standard Definition Recording Capability

Responding to the needs of the industry, the GY-HM750U, in addition to its capability as an HD recorder, offers Standard Definition recording for maximum flexibility. Recording in SD provides a time-saving alternative to down-conversion of HD material for SD



Innovation to Meet the Needs of Professionals — Native File Recording Capability

The Next Generation of Native File Access Workflow

Native File Recording for Integrated Workflows

With Native File Recording, JVC has eliminated one of the main obstacles to achieving a smoother, more streamlined production workflow. Until now, ingesting footage into editing systems was a time consuming process. With Native File Recording, your footage is ready to edit the moment it's shot.

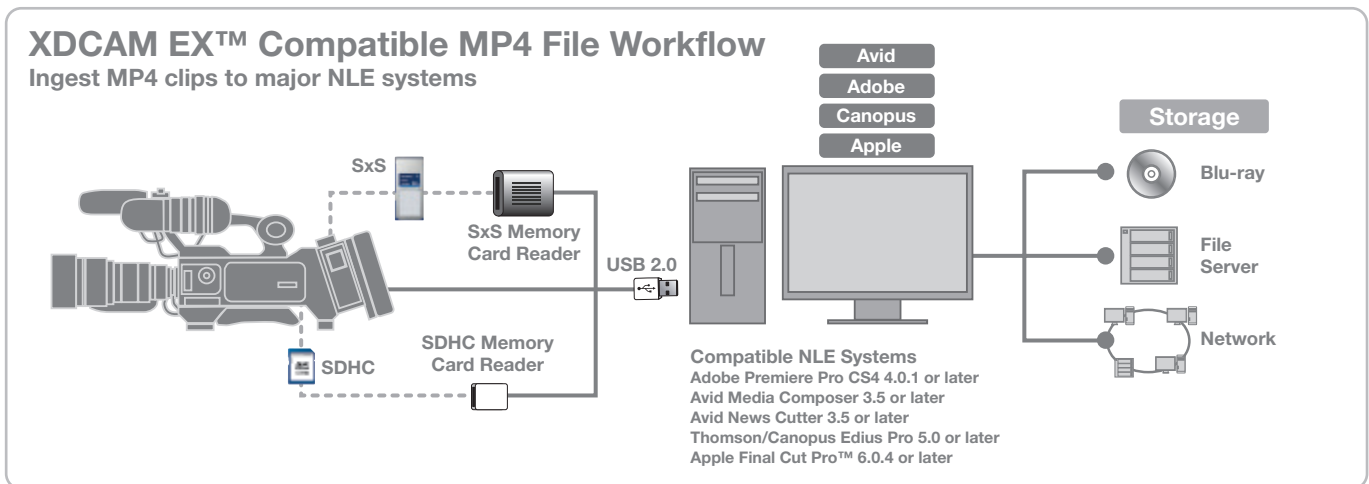
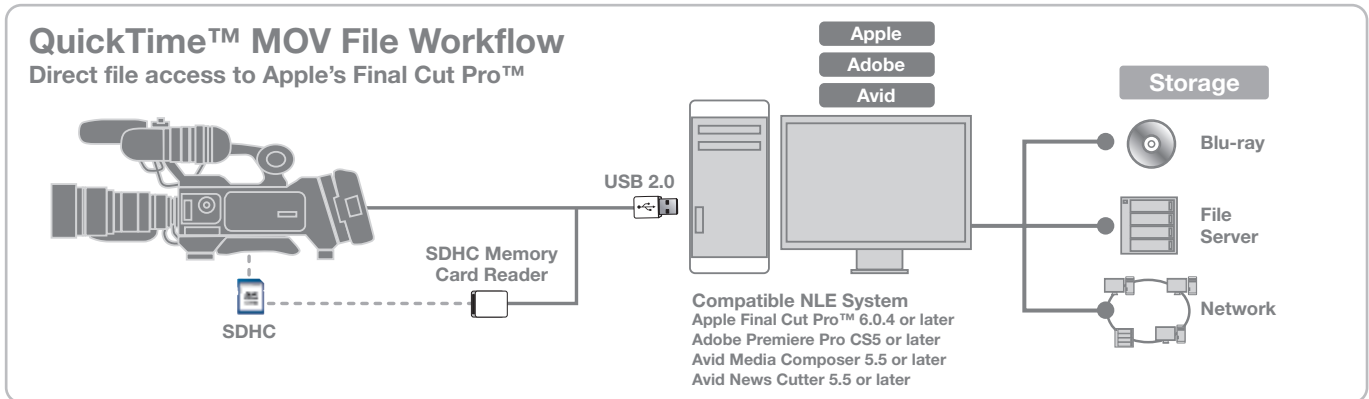

Dual Format Recording (QuickTime™ for FCP™/XDCAM EX™ Compatible MP4)

Because it uses QuickTime™ as its native file format, the GY-HM750U is the perfect choice for users of Apple's Final Cut Pro™ editing system. Both HD and SD MOV files recorded by the camcorder can be dropped directly into Final Cut Pro™, keeping them first-generation and eliminating the time-consuming process of file conversion. You'll spend less time preparing the files for editing, and more time letting your creativity get to work.

For users of all major NLE systems, including solutions from Adobe, Avid, Canopus, Vegas and Apple, the GY-HM750U supports the MP4 file format, which can be brought into your editing system without re-encoding. HDV-compatible M2T files can also be created from these MP4 files using the ProHD Clip Manager (Version 1.1).

Finally, the popular type-2 AVI file format can be recorded in SD for easy import into almost all current and legacy NLE systems.

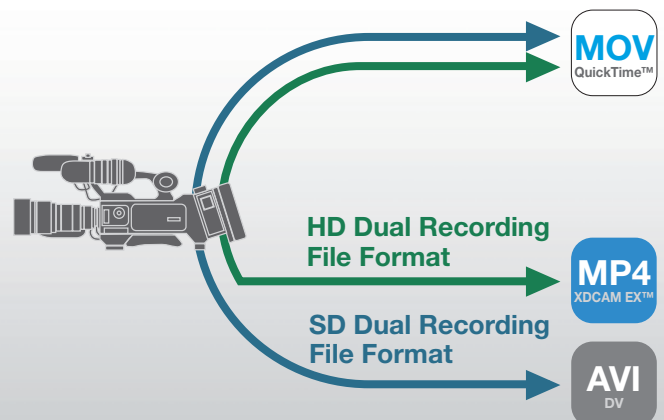

ProHD Software

Dual SDHC Card Slots for Simultaneous or Seamless Relay Recording

Dual SDHC card slots make the GY-HM750U a truly versatile camcorder. Using standard, inexpensive and widely available Class-6 or Class-10 SDHC cards, footage can be recorded either to both cards simultaneously, or from one card to the other in relay. Simultaneous recording means you can easily create backup or duplicate files as you shoot without the need for any external equipment — either for a client copy or simply for peace of mind. In relay recording mode you can shoot continuously and seamlessly over multiple cards. When one card is full, the camcorder switches seamlessly and automatically to the other card. And because cards are hot swappable, there is in effect no limit to the continuous shooting time in any mode, even with lower capacity cards. Hot swappable media also means it is possible to start editing footage from one card while still shooting to the other. The dual card slots also offer the flexibility of scene-by-scene card selection.



Simultaneous Recording

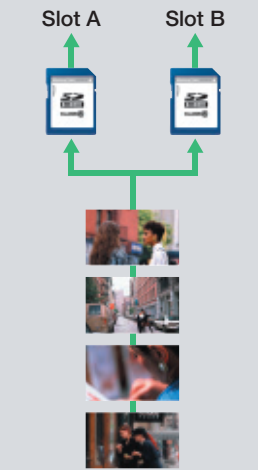

Relay Recording

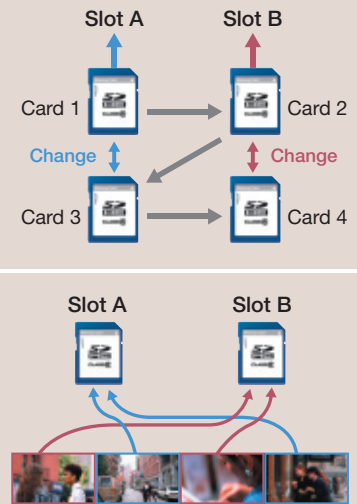

SDHC media offers the best combination of price, availability, capacity, reliability and transfer speed. With no moving parts and no pins or other extrusions, SDHC cards are both durable and reliable, and compare favorably with tape on a cost-per-minute basis.

SxS Double Media Hybrid Recording (Optional)

The optional SxS media recorder allows simultaneous shooting to SDHC and SxS media. This hybrid recording system provides a reliable backup solution.



JVC ProHD Clip Manager

The ProHD Clip Manager for both Mac and Windows makes it easy to manage MP4 clips on the GY-HM750U's memory cards from your computer. With a few clicks of the mouse you can copy, move or delete clips, preview clip content, as well as view and edit clip metadata. A thumbnail view of all the clips in the current folder shows the content of each clip at a glance. Use the viewer to watch the whole clip, or change the clip's index frame used for the thumbnail. You can also manage folders to keep your clips organized, and check the remaining free space on a card. The latest version of ProHD Clip Manager offers an even greater level of NLE compatibility by enabling MP4 files to be converted to m2t widely supported by NLEs.



Main screen for Windows®

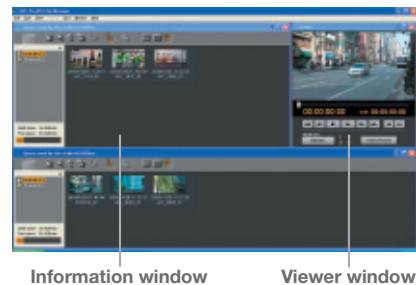

ProHD Log and Transfer Plug-in

The ProHD Log and Transfer Plug-in is a plug-in for Apple's Final Cut Pro™ that lets you drop MP4 files recorded on the GY-HM750U into the clip bin.

With the plug-in installed, you can view thumbnails of the MP4 files on a memory card from the Log and Transfer screen of Final Cut Pro™. Simply drag and drop the thumbnails into the bin to automatically convert the clips to QuickTime™, ready for use.

Log and transfer screen

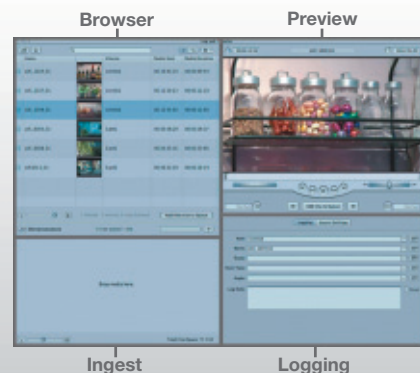

* Playback compatibility not guaranteed on all products due to variation of supported recording mode.

* MP4 is the compliant file format used on the XDCAM EX™.

* SxS is a flash memory card designed for professional video cameras with a high-speed PCI Express interface.

* All trademarks and brand names are the property of their respective proprietors.

Innovation that Meets the Needs of Professionals — Ease of Operation

Ease of Operation for Complete Creative Freedom

1.22 Megapixel LCOS Viewfinder and Focus Assist Function

The GY-HM750U features a stunning new high-resolution (852 x 480 x 3) LCOS (Liquid Crystal on Silicon) 0.45" viewfinder. The 16:9 aspect ratio image is crisper and more detailed than conventional LCD viewfinders, with higher vertical resolution and superior RGB color separation. Helping the camera operator stay focused on the action is a focus assist system that highlights the edges of objects in the image. Also visible in the viewfinder are indicators for the audio input level, the battery time remaining, and the recording time available on each memory card.



Focus Assist

With the increased resolution of HD, accurate focusing is critical — focusing errors that may pass unnoticed in SD video are far more obvious when watching in HD. JVC developed Focus Assist to make accurate HD focusing quick and easy. When Focus Assist is switched on, the image in the viewfinder or LCD monitor becomes monochrome and all objects that are in focus appear with colored edges. Keeping the important elements in the picture in focus while shooting is greatly simplified.



Focus Assist OFF



Focus Assist ON

4.3-inch LCD Monitor

The large, high-resolution 4.3-inch 16:9 aspect ratio LCD monitor provides a wide array of monitoring and setup indications. The monitor's 800 x 480 WVGA resolution, together with the easy-to-use cross keys for GUI navigation, bring ease of use to a new level for a professional camcorder.

Spot Exposure Meter

When shooting high-contrast scenes, setting the exposure accurately can become tricky. The Spot Meter allows you to monitor the dynamic range of the image in various ways so that the exposure may be controlled more accurately. A manual mode allows a specific area of the image to be monitored for precise exposure control of the main subject in the frame. There are four modes of spot metering: Max/Min, Max, Min and Manual. In the Max/Min mode, the highest and lowest levels of the image are identified with color markers, red (H) and white (L), along with the video level (before knee and gamma).



GUI

All on-screen monitors can be navigated intuitively via a four-way cross key and a central Set button. A colored LED ring illuminates the outer edge of the cross keys, indicating the current camera mode. The GUI can be viewed in both the LCD monitor and overlaid in the viewfinder. The high-resolution picture thumbnail display makes it a simple task to select clips visually for review, and more detailed file and file format, frame rate, resolution and time code data.



File content display



Menu display

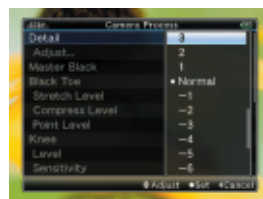

Item select over picture



Favorite menu display

Shooter-Friendly Controls and Layout

The control panel of the GY-HM750U has been laid out so that all commonly used controls are within easy reach of the operator while shooting. Among the controls are three user-definable buttons that can be assigned a range of functions for instant setting.



Pre Rec Mode

How many times have you missed a crucial moment because you didn't hit the record button in time? With Pre Rec enabled, the camcorder continuously buffers up to 20 seconds of video, so that when recording is started the cached video is included in the recorded file, giving you up to 20 second head start.

Normal Rec



Pre Rec

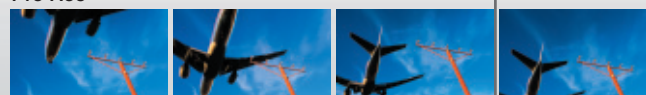

Retro cache recording period (Up to 20 sec.)

Optional ASI Adapter

JVC's proprietary 68-pin interface allows direct docking of the optional ASI (Asynchronous Serial Interface) Adapter which provides a low-latency ASI output of the camcorder's MPEG2 data stream.



GY-HM750U with optional KA-AS790G

Remote Camera Control Connector

The GY-HM750U is equipped with a standard JVC 6-pin TTL interface for an optional remote camera controller (RM-LP25U or RM-LP55U). These units provide extensive control options, including paint, iris, gamma level, knee, gain, shutter, and black level.



Variable Frame Rate Recording (Over Crank, Under Crank)

When recording in the 720p 35 Mbps mode, the camera can be set to record at a frame rate different than the playback rate. This capability makes it possible to record slow or fast motion when the recording is played back at 24p, 25p or 30p.

Versatility and Quality of Output

SDI and IEEE1394 Output

In addition to SD composite and HD/SD component video output, the GY-HM750U is equipped with SDI and IEEE1394 outputs. The SDI output is via a BNC connector and can be switched between HD and downconverted SD with embedded uncompressed audio. The IEEE1394 output is via a 4-pin connector and can also be switched between HD and SD by menu. The audio output is HDV compliant in HD mode and DV compliant in SD mode.

Composite out



Component out SDI out IEEE1394 out

Dimensions

Unit: inches (mm)

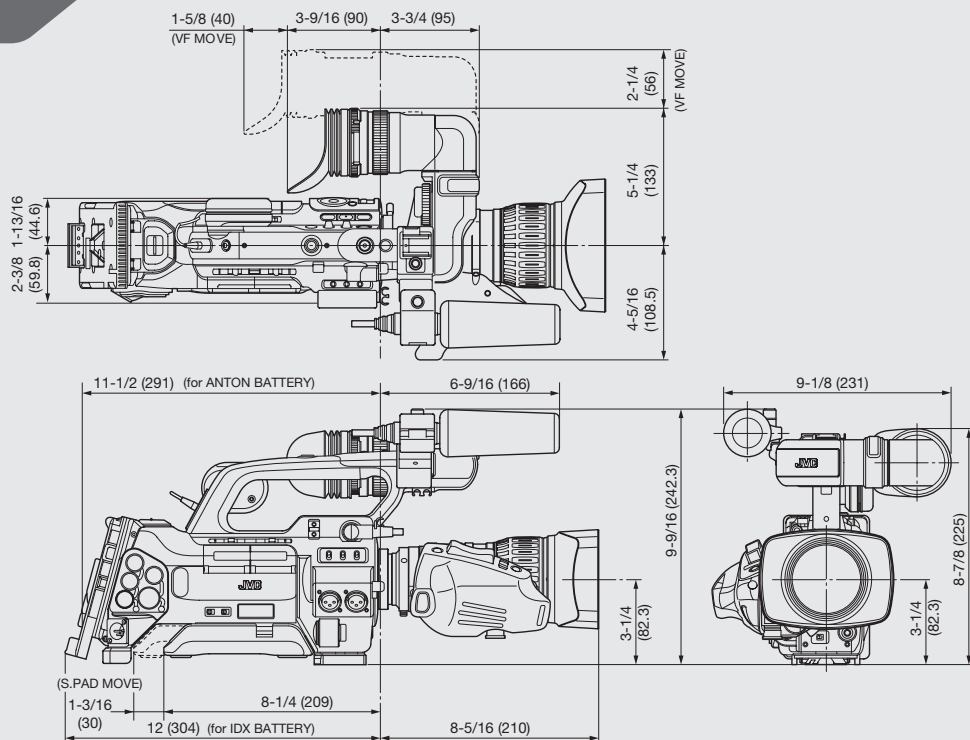

System Configuration

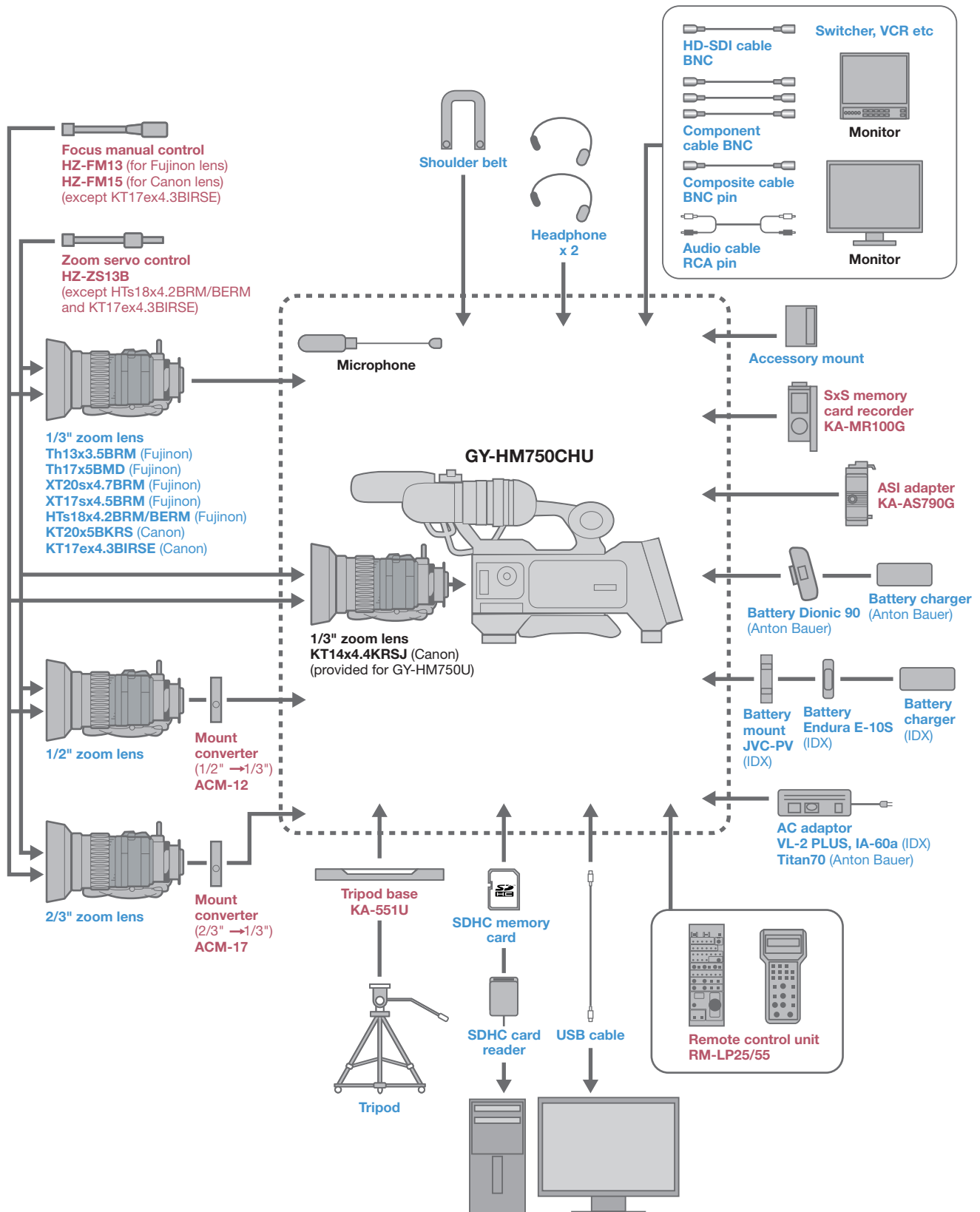

Optional Accessories



(Canon)

KT20x5BKRS
1/3" high quality zoom lens



(Canon)

KT17ex4.3BIRSE
1/3" high quality zoom lens
with 2x extender



(Fujinon)

HTs18x4.2BRM
HTs18x4.2BERM (2x extender)
1/3" high quality zoom lens



(Fujinon)

XT17sx4.5BRM
XT20sx4.7BRM
1/3" zoom lens



(Fujinon)

Th17x5BRMD
1/3" MD zoom lens



(Fujinon)

Th13x3.5BRM
1/3" wide zoom lens



ACM-12
1/2" Bayonet mount converter



ACM-17
2/3" Bayonet mount converter



HZ-CA13U
16mm film lens adapter



RM-LP25U RM-LP55U

RM-LP25U (Desk mount)
RM-LP55U (Handheld)
Remote control unit
6-pin DIN



HZ-ZS13BU
Manual zoom control
Cannot be used for HTs18x4.2BRM lens.
Use Fujinon ZMM-6: Module unit/CZH-14:
Grip/CFC-12-990: Cable/MCA-7: Mounting clamp



HZ-FM13U (Fujinon)
HZ-FM15U (Canon)
Manual focus control



KA-551U
Tripod base V-mount adapter



KA-MR100G
SxS memory card recorder



KA-AS790G
ASI adapter



SR-HD1500US
Blu-ray disk recorder



**DT-V24G1Z/V20L3GZ/
V17G1Z/V9L3DY**
LCD HDTV monitor



**DT-R24L4DU/
DT-R17L4DU**
LCD HDTV monitor



JVC-PV
IDX V-mount plate



Endura E-10S (Battery)
IDX V-mount battery



VL-2PLUS (Charger)
IDX V-mount battery charger/
AC adapter



Dionics 90 (Battery)
Anton Bauer battery



Tandem 70 (Charger)
Anton Bauer battery charger/
AC adapter

Specifications

GY-HM750U

[General]

Power requirement: DC 12 V (11 V to 17 V)
 Power consumption: Approx. 24 W (during recording [when the camcorder + standard lens + LCD monitor are in use])
 Mass: Approx. 3.4 kg (7.7 lbs.)
 Temperature:
 Operating: 0°C to 40°C (32°F to 104°F)
 Storage: -20°C to 60°C (-4°F to 122°F)
 Humidity:
 Operating: 30% to 80% RH
 Image pickup device: 3-chip 1/3" Progressive CCD
 Color separation prism: F1.4, 3-color separation prism
 Sync system: Internal sync (built-in SSG)
 Lens mount: 1/3" bayonet system
 ND filter: OFF, +1/4ND, +1/16ND
 Gain: 0dB, 3dB, 6dB, 9dB, 12dB, 15dB, 18dB, ALC
 Electronic shutter: 1/6 to 1/10000, EEI
 Minimum illumination: 1.25lx (typical) (1920x1080 mode, F1.4, +18dB, with 8-frame accumulation)
 LCD monitor: 4.3" LCD, 800 x 480 (WVGA, 410,000 pixels)
 Viewfinder: 0.45" LCOS, 1.22 Megapixels (852 x 480 x 3)
 Lens: Canon F1.6, 14x, f = 4.4-61.6 mm (35 mm conversion: 32 to 448 mm)
 Filter diameter: 82 mm
 Supported media: SDHC (Class 6 or 10)
 Slots: x 2
 Recording time: Approx. 25 minutes (8 GB SDHC card, 35 Mbps, VBR mode)

■ SDHC Class 6 or 10 recording time (approx.)

| | MOV/MP4 | | MOV/AVI | |
|------|---------------|---------------|---------------|---------|
| | SP | HQ | SD | |
| | 720p | 1080i | 720p/1080i | 480i |
| 4GB | 22 min. | 17 min. | 12 min. | 15 min. |
| 8GB | 45 min. | 35 min. | 25 min. | 30 min. |
| 16GB | 1 hr. 30 min. | 1 hr. 10 min. | 50 min. | 1 hr. |
| 32GB | 3 hr. | 2 hr. 20 min. | 1 hr. 40 min. | 2 hr. |

[Video/Audio]

Recording file format: QuickTime™ File Format for Final Cut Pro™ (HD/SD)/MP4 File Format (HD)/AVI type-2 File Format (SD)
 Recording format:
 HD Video: MPEG-2 long GOP
 HQ mode: VBR, 35 Mbps (1920x 1080i50/60, p24/25/30) MPEG-2 MP@HL
 SP mode: CBR, 25 Mbps (1440x1080i50/60, p24/25/30)/19 Mbps (1280 x 720p24/25/30): MPEG-2 MP@H-14
 19 Mbps (1280 x 720p50/60): MPEG-2 MP@HL
 SD Video: DV compression 4:1:1, b-bit, 25Mbps
 Audio: LPCM 2ch, 48 kHz/16bit; SD LPCM 2 ch, 48kHz/16-bit
 Video frame rate:
 NTSC settings:
 HD HQ mode: 1920 x 1080/59.94i, 29.97p, 23.98p,
 1440 x 1080/59.94i, 1280 x 720/59.94p, 29.97p, 23.98p
 HD SP mode: 1440 x 1080/59.94i, 1280 x 720/59.94p, 29.97p, 23.98p
 PAL settings:
 HD HQ mode: 1920 x 1080/50i, 25p, 1440 x 1080/50i, 1280 x 720/50p, 25p
 HD SP mode: 1440 x 1080/50i, 1280 x 720/50p, 25p
 Variable frame rate (HQ 720p mode):
 NTSC settings: 10/12/15/20/24/30/40/48/60 fps
 PAL settings: 10/12.5/20/25/40/50 fps

[Connectors]

Analog composite output (480i or 576i: Downconverted, 4:3/16:9): 1.0 V (p-p), 75-ohms, BNC (unbalanced; switchable from analog component Y output)
 Analog component output (480i or 576i; Downconverted, 720p/1080i): Y: 1.0V (p-p), 75-ohms Pb, Pr: 0.7V (p-p), 75-ohms, BNC x 3 (unbalanced)
 SDI output terminal (480i or 576i: Downconverted/720p/1080i: embedded audio), BNC (unbalanced)
 HD-SDI: Compliant with SMPTE 292 M
 SD-SDI: Compliant with SMPTE 259 M
 Audio input:
 [MIC]: -60 dBμ, 3k-ohms, XLR (balanced), +48 V output (phantom power supply)
 [LINE]: +4 dBμ, 10k-ohms, XLR (balanced)
 Audio output: -8±1 dBμ (when audio signal process output is -20 dB), 1k-ohms, RCA x 2 (unbalanced)
 Headphone: 3.5 mm mini jack (stereo) x 2
 Remote: DIN 6-pin
 IEEE1394 output: 4-pin USB: Mini USB-B type, USB 2.0, miniB, slave function (mass storage class) only
[Accessories Provided]
 Microphone x 1

Final Cut Pro™ is not supplied.
 Microsoft® and Windows® are either registered trademarks or trademarks of Microsoft Corporation in the United States and/or other countries. Apple, Apple logo, Macintosh, QuickTime, and Final Cut Pro are trademarks of Apple Inc. registered in the United States and other countries. The SD and SDHC logos are trademarks of the SD Card Association.
 HDV and HDV logo are trademarks of Sony Corporation and Victor Company of Japan Limited (JVC).
 Product and company names mentioned here are trademarks or registered trademarks of their respective owners

Simulated pictures.
 The values for weight and dimensions are approximate.
 E.&O.E. Design and specifications subject to change without notice.



DISTRIBUTED BY



JMI-0181



091

Business Solution Division of Victor Company of Japan, Ltd. has received ISO9001 Certifications.